

# 4000AE™



The First Name In Trailers®

## Weight to be Amazed By our sleek new 8,840\* lb powerhouse

Utility engineers have designed a next-generation flatbed that remains true to the company tradition of building trailers proven to be both light weight and strong. The 4000AE™ Combo is a completely re-designed and re-engineered trailer, which not only weighs less, but is stronger than its predecessor. In fact, it out-performed the previous design on Utility's torture test track. Our engineers did not simply remove weight by changing to aluminum crossmembers, but changed the way the crossmembers and mainbeam work together to support the load. This was achieved by a patent-pending new crossmember system, using a

combination of both 3" and 4" deep aluminum crossmembers, where the crossmembers are both uniquely suspended and supported.

The rugged 4000AE weighs less than some all-aluminum trailer designs, yet is available at a combo-trailer price. It comes standard with a 47,000 lb coil haul package, yet weighs 536 lb less than the 4000A® base combo model, and 627 lb less than the 4000A flatbed when spec'd with an optional coil haul package. The 4000AE is the most efficient and productive flatbed available, providing long-term value and lower total cost of ownership.



\*8,840 lb weight indicates the 4000AE base spec model with steel disc wheels

© 2017 Utility Trailer Manufacturing Co., 17295 Railroad St, City of Industry, CA 91748

[www.utilitytrailer.com](http://www.utilitytrailer.com)

# HEAVY-DUTY, LIGHT WEIGHT FEATURES



The First Name In Trailers®



## 47,000 lb Coil Haul Package

Nine 4" aluminum, full width tapered crossbars on 8" centerlines provide optimized strength.

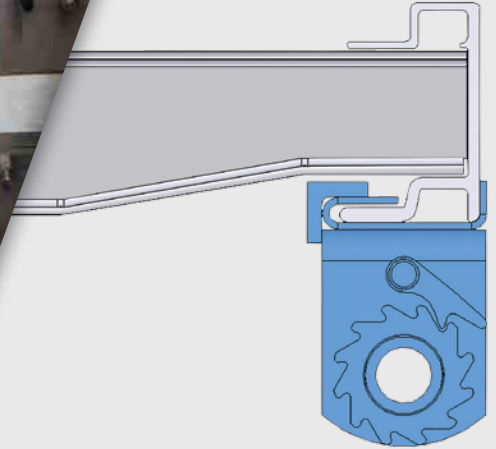

## Light, High Strength, Low Maintenance

Lighter than the other members of Utility's flatbed family, there is no compromise on quality or strength. The 4000AE strikes the right balance between steel and aluminum to provide the strength and durability of an all-steel trailer and the low weight of an all-aluminum trailer. The main beams are shot blasted prior to painting and then coated with a two-part primer and two-part urethane top coat on the exterior surfaces and a rust preventative coating is applied to the interior surfaces for lower maintenance cost.



## High Strength Aluminum Floor with Nail Strips

The extruded aluminum floor adds strength and lateral stiffness to the 4000AE without adding weight. The 4000AE comes standard with two hard wood nailing strips for securing load dunnage. An optional third nail strip in the center of the trailer is available if needed.

\* Specifications, data, and images are subject to change without notice.

**4000AE**